

In close proximity to historic Findlay Market, August Flats is the renovation of three historic buildings at Race and Green streets in Over-the-Rhine. The completion of the project resulted in 3,250 square feet of white box commercial space at 1701-1705 Race Street.





This brochure is for illustration purposes only and not part of a legal, binding contract. Information is subject to change without notice.

Please consult with a 3CDC representative for complete and up-to-date information 01/2024.

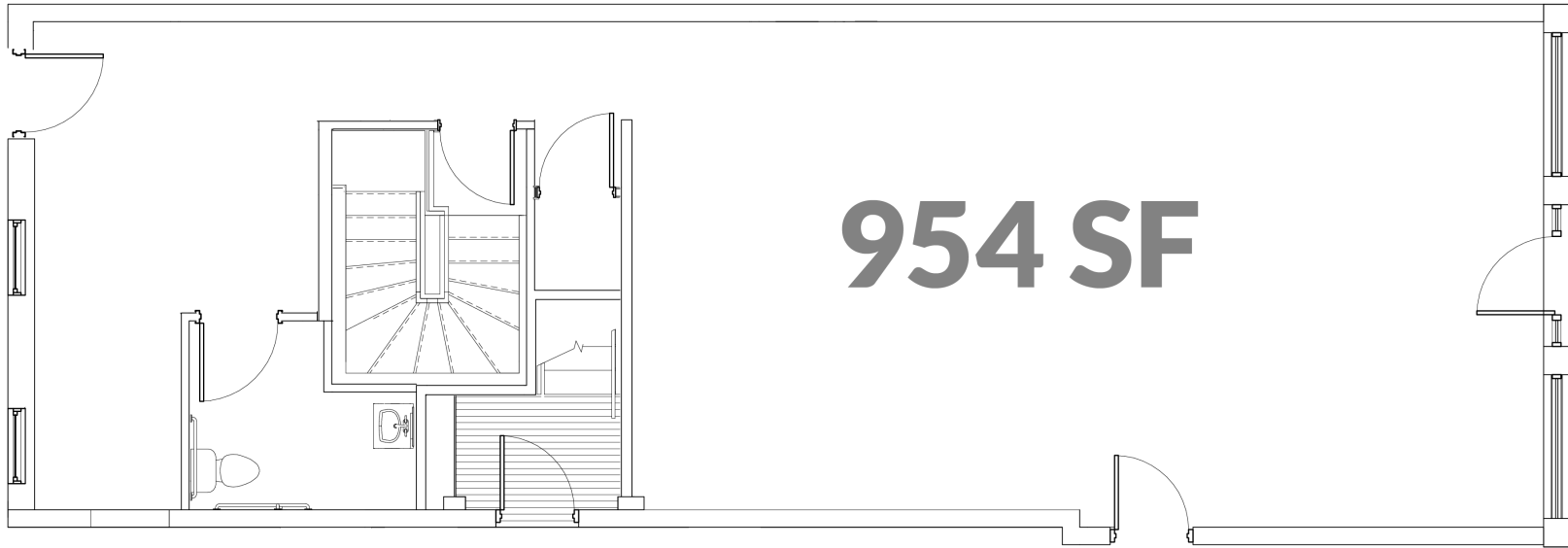

This brochure is for illustration purposes only and not part of a legal, binding contract. Information is subject to change without notice.

Please consult with a 3CDC representative for complete and up-to-date information 01/2024.

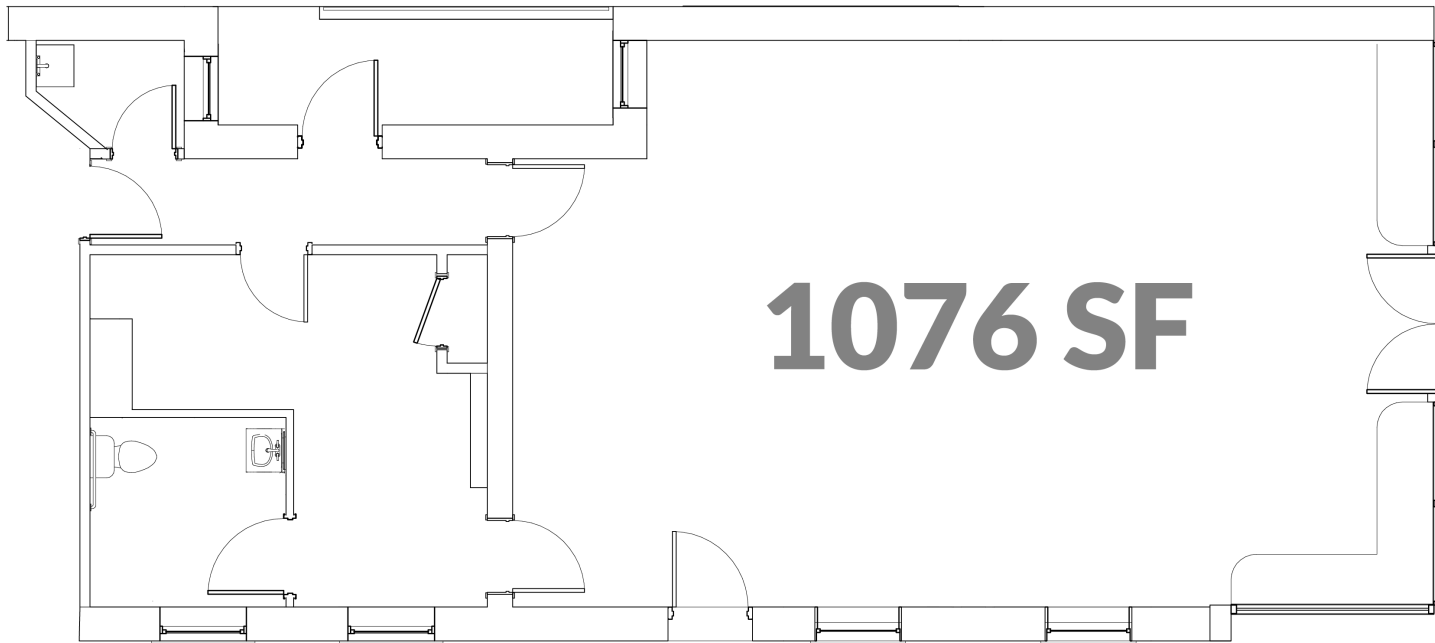

This brochure is for illustration purposes only and not part of a legal, binding contract. Information is subject to change without notice.

Please consult with a 3CDC representative for complete and up-to-date information 01/2024.

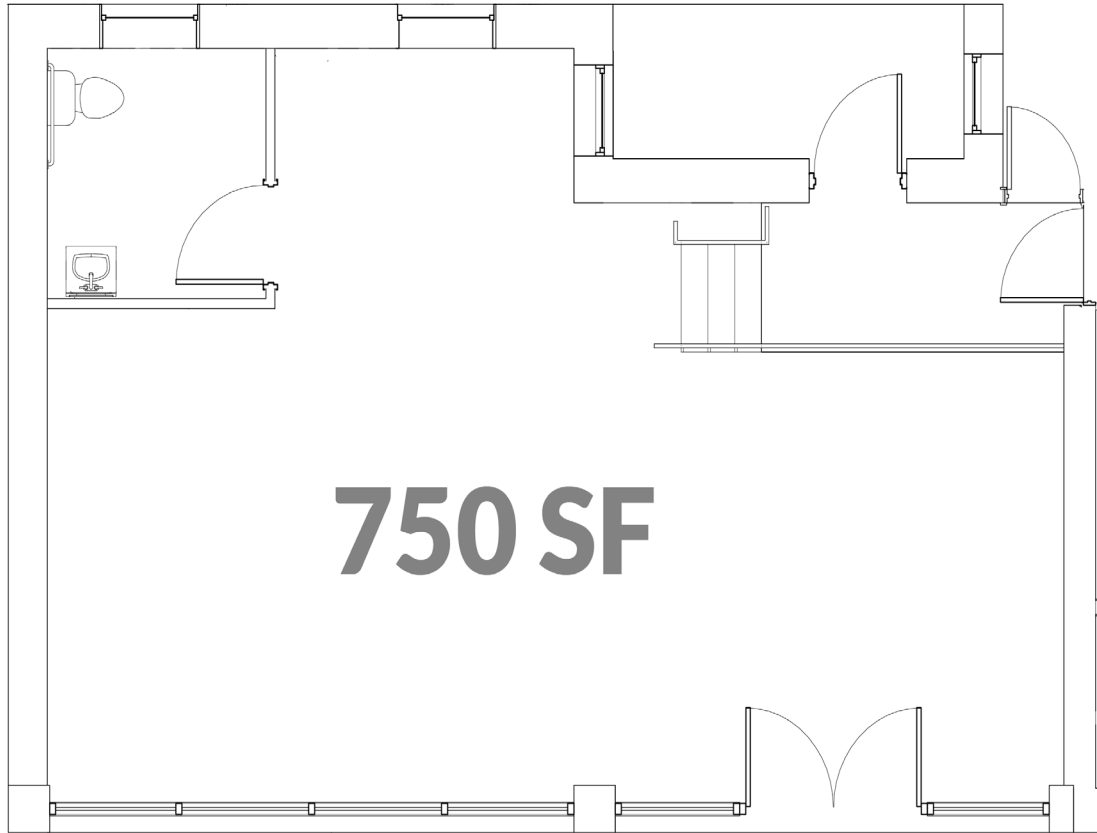

This brochure is for illustration purposes only and not part of a legal, binding contract. Information is subject to change without notice.

Please consult with a 3CDC representative for complete and up-to-date information 01/2024.